

I - Ionian Mode (Major Scale)

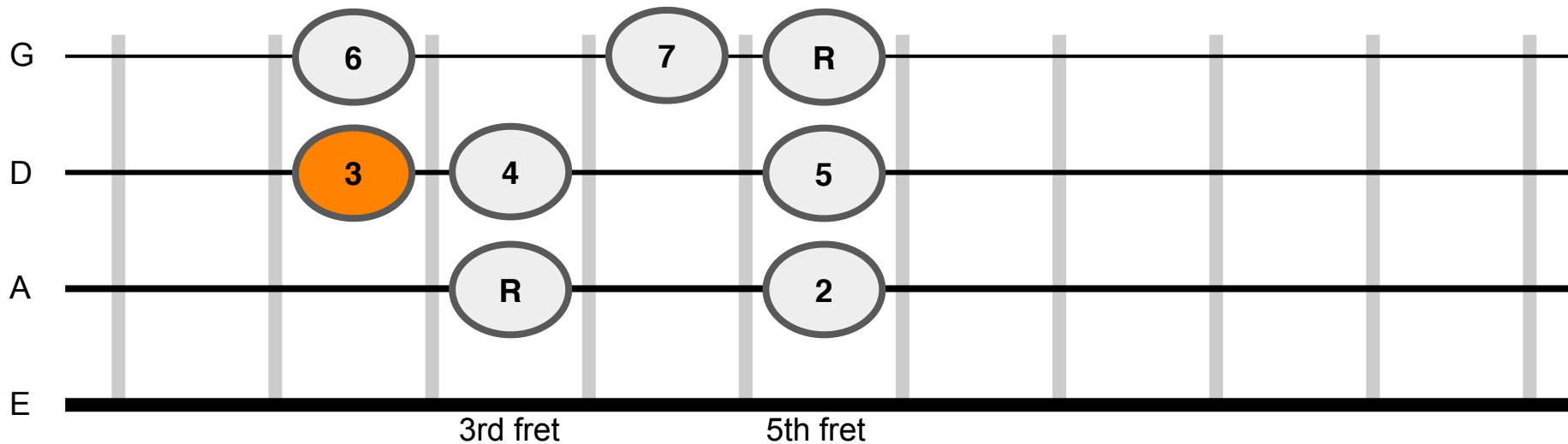

I - Ionian Mode (Major Scale)

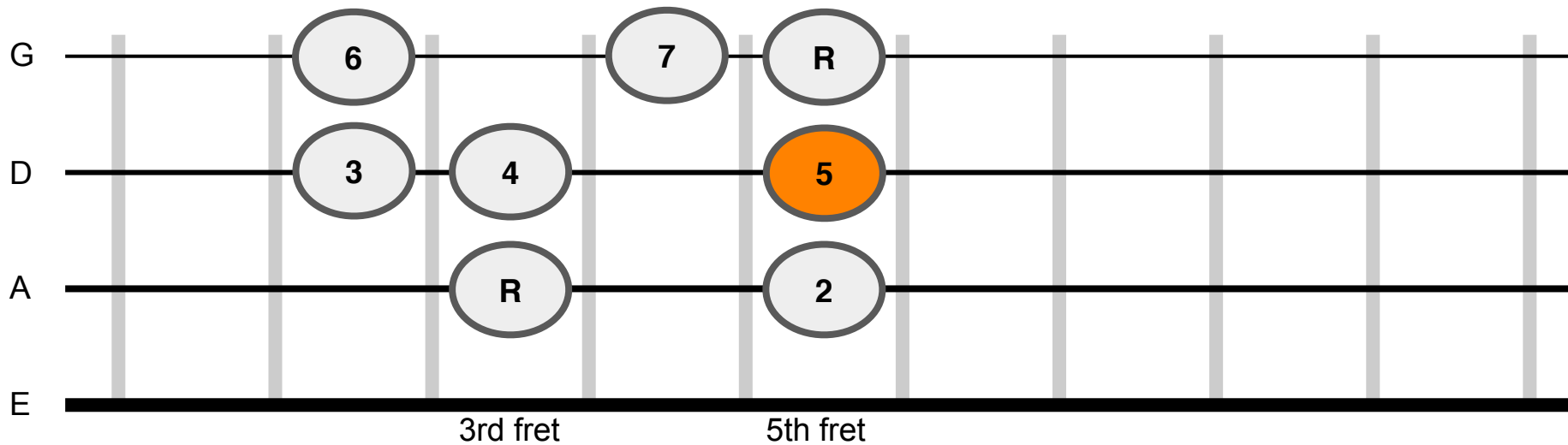

I - Ionian Mode (Major Scale)

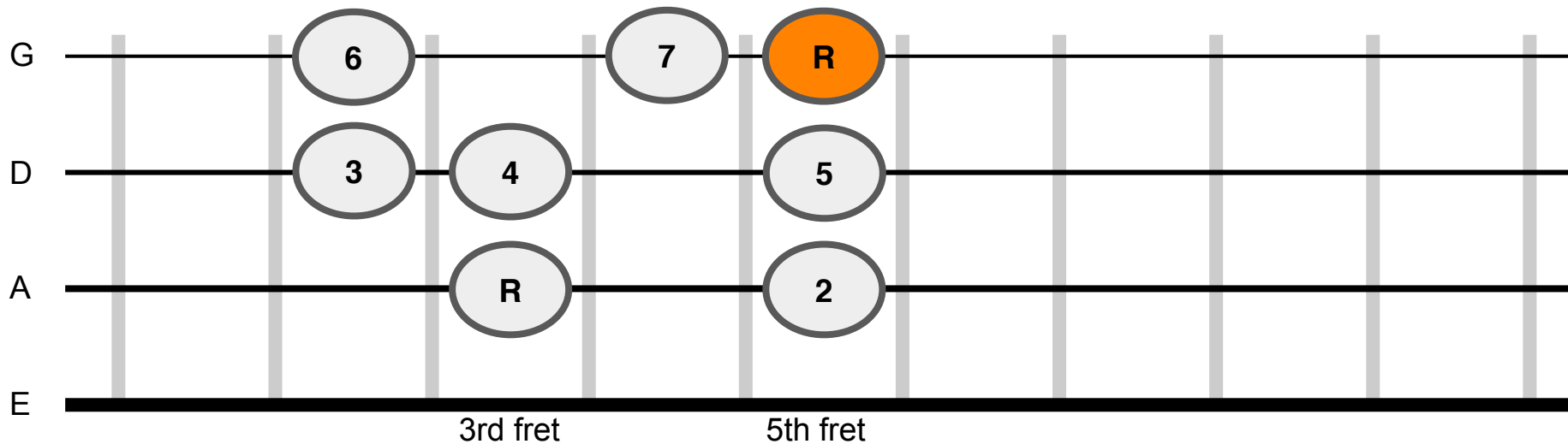

I - Ionian Mode (Major Scale)

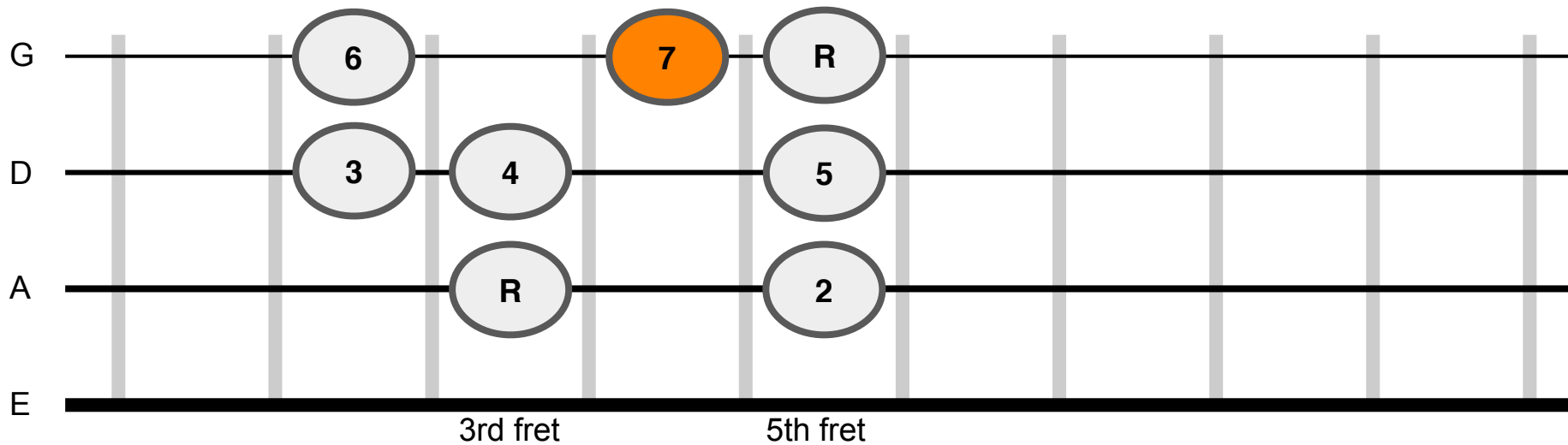

I - Ionian Mode (Major Scale)

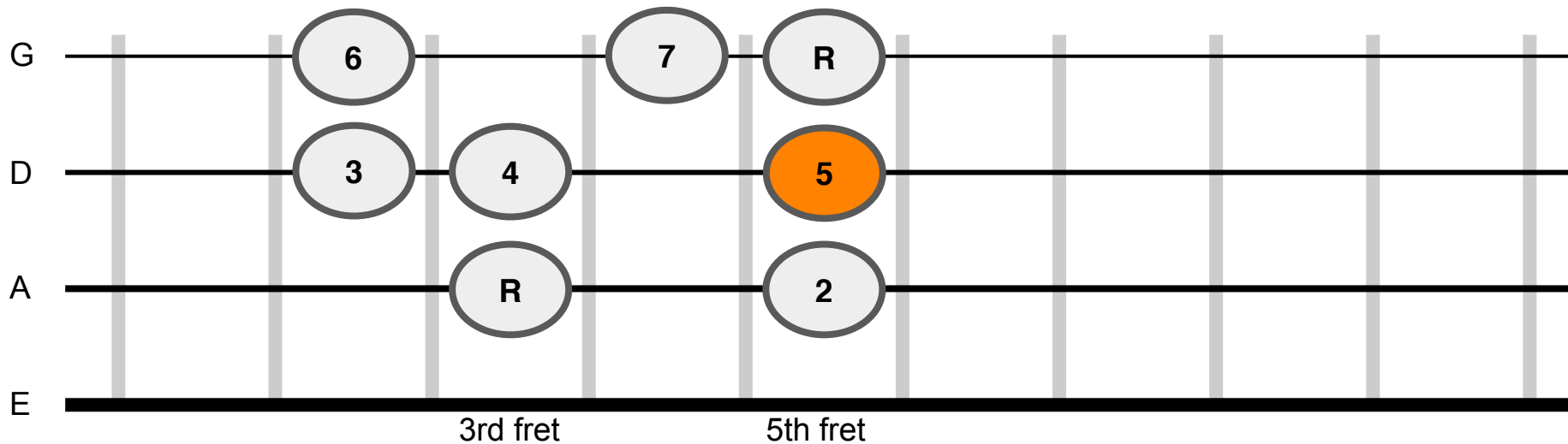

I - Ionian Mode (Major Scale)

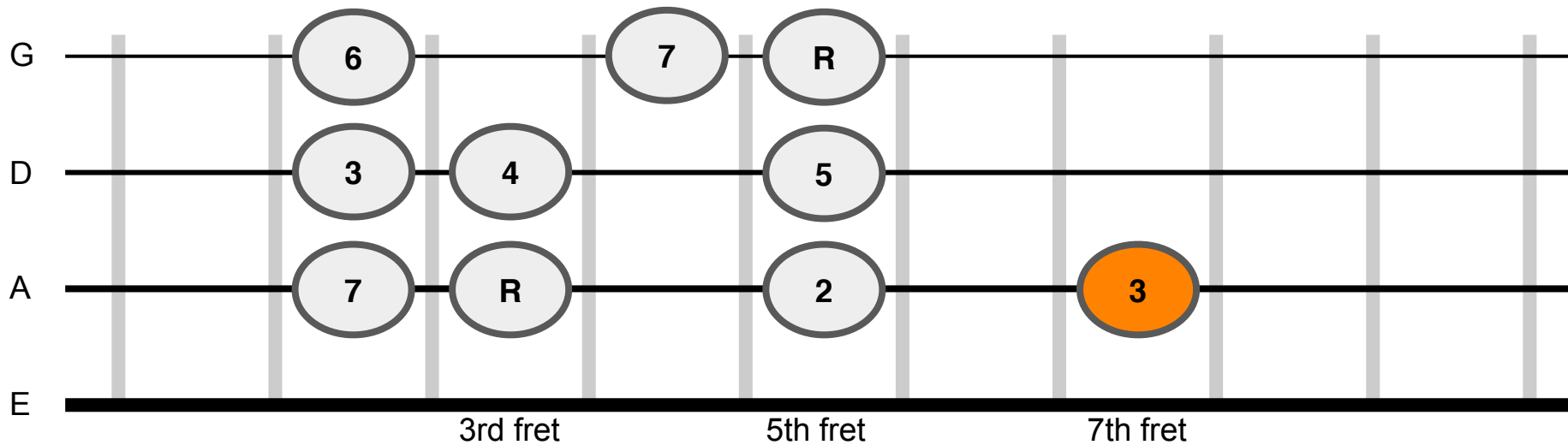

I - Ionian Mode (Major Scale)

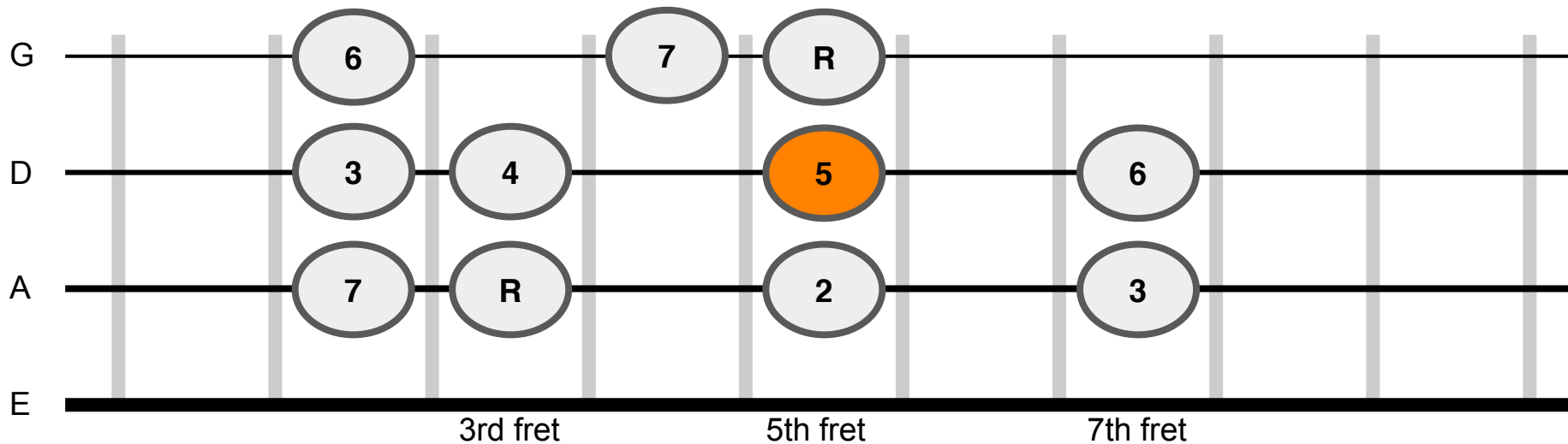

I - Ionian Mode (Major Scale)

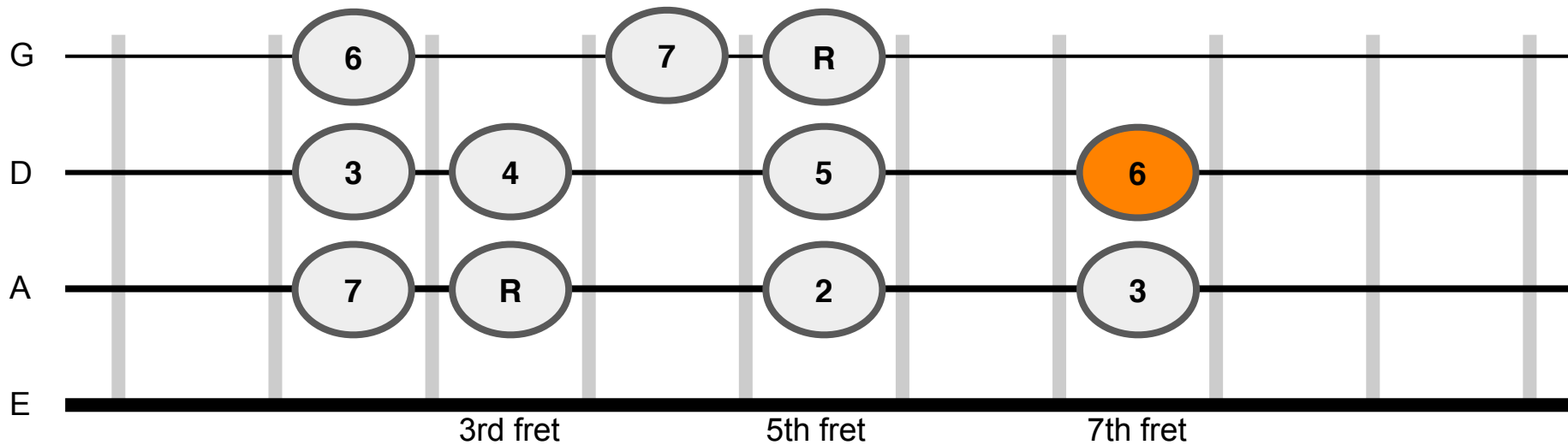

I - Ionian Mode (Major Scale)

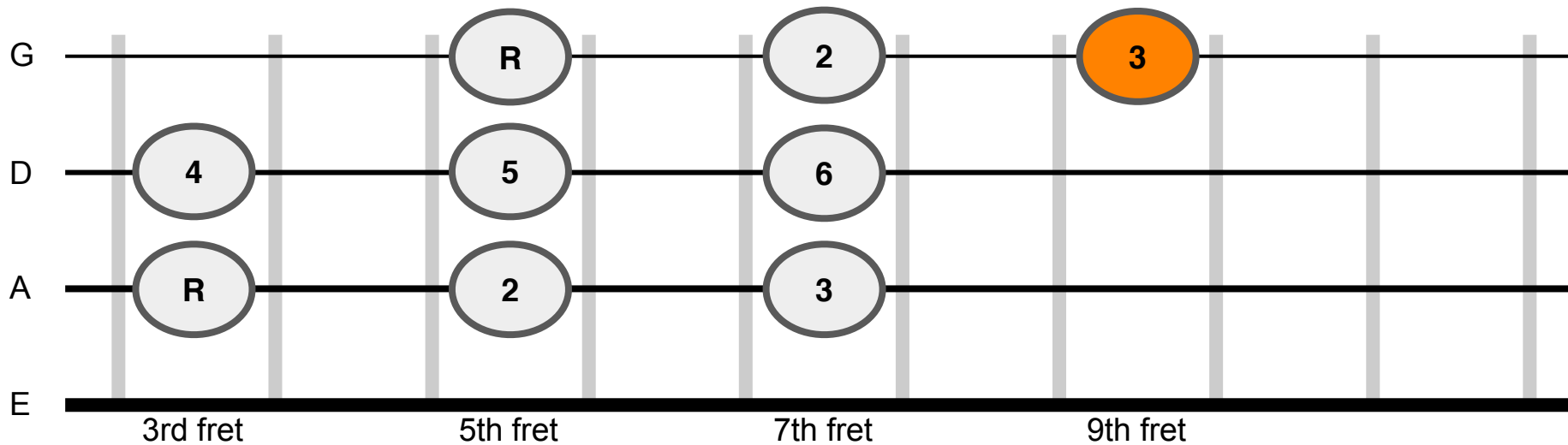

I - Ionian Mode (Major Scale)

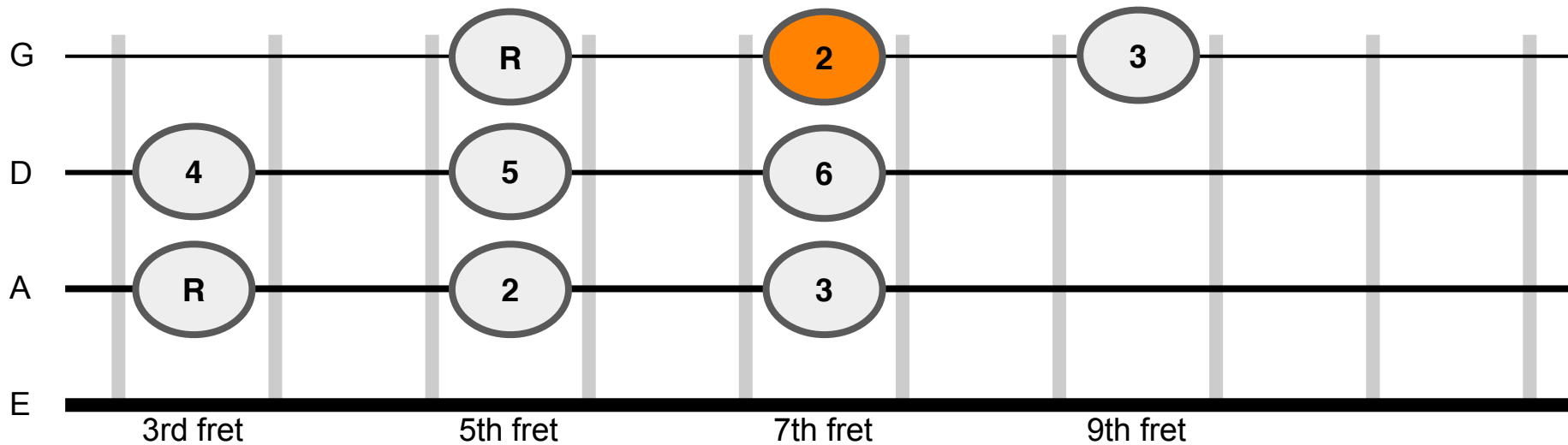

I - Ionian Mode (Major Scale)

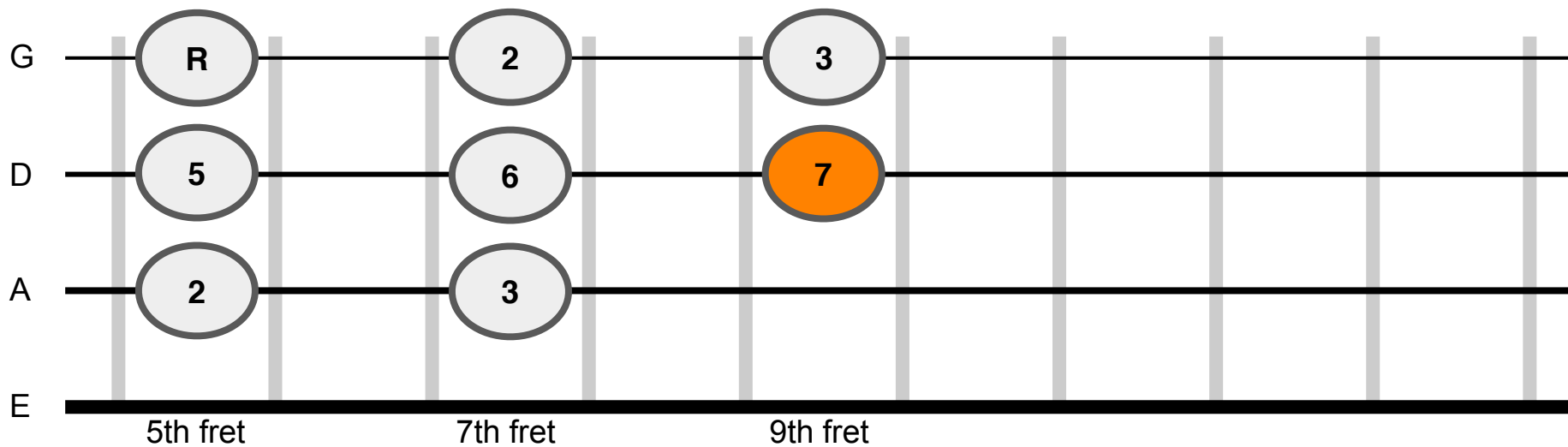

I - Ionian Mode (Major Scale)

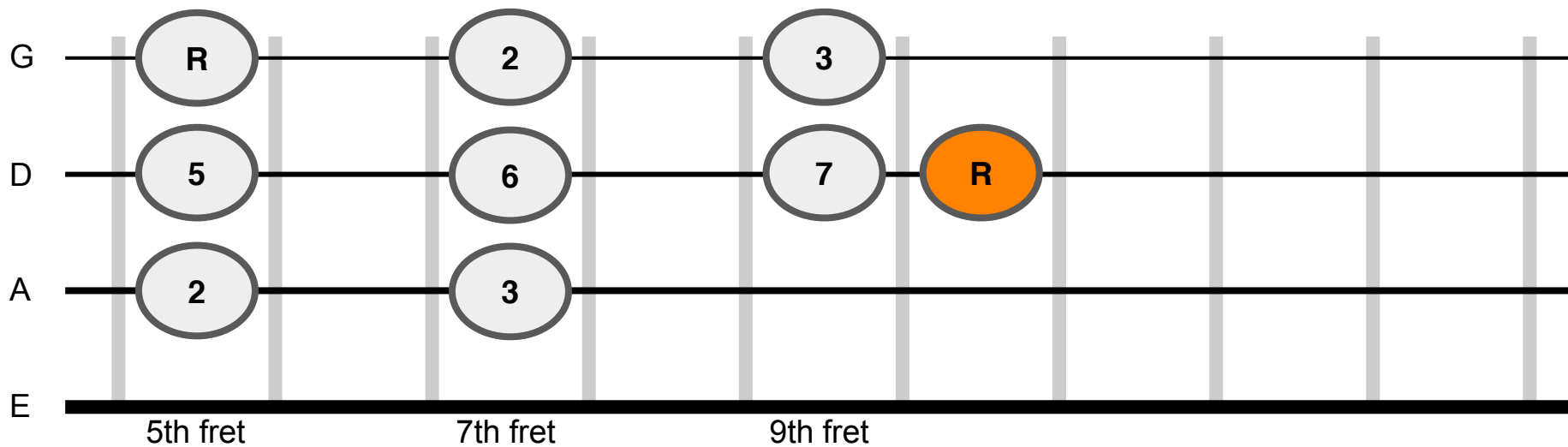

I - Ionian Mode (Major Scale)

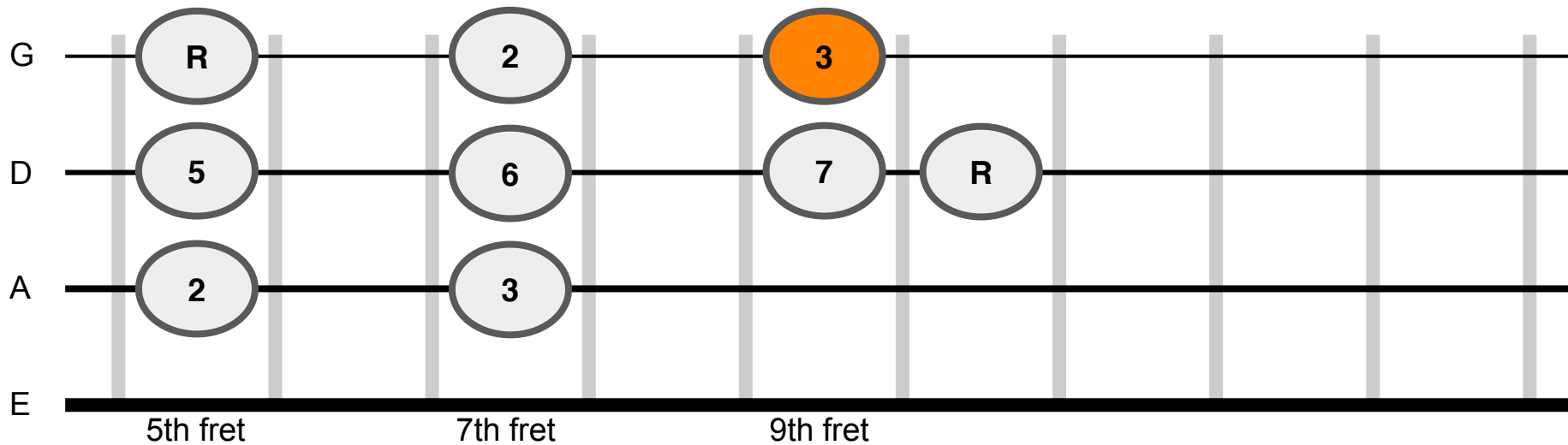

I - Ionian Mode (Major Scale)

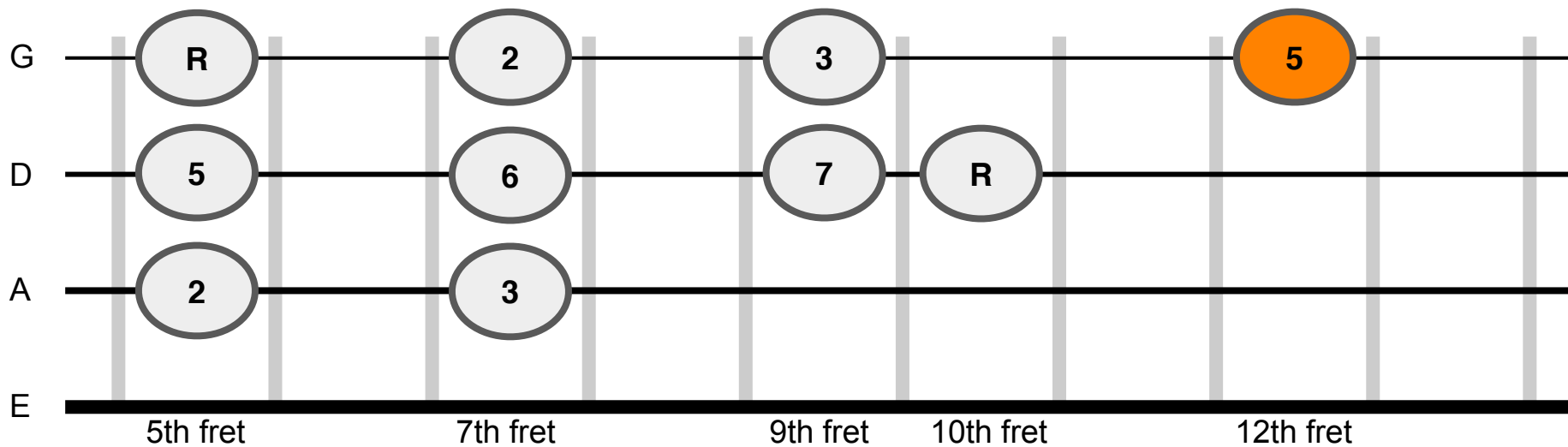

I - Ionian Mode (Major Scale)

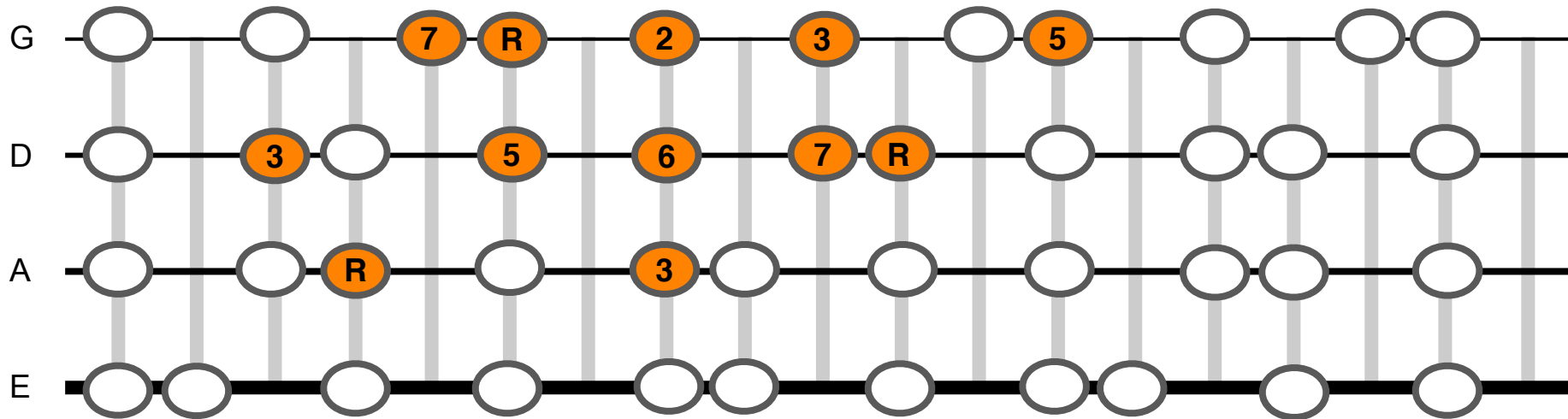

Eagle's Eye Chord Tones

Lick Order: R, 3, 5, R, 7, 5, 3, 5, 6, 3, 2, 7, R, 3, 5

test: can you fill in the missing scale tones?

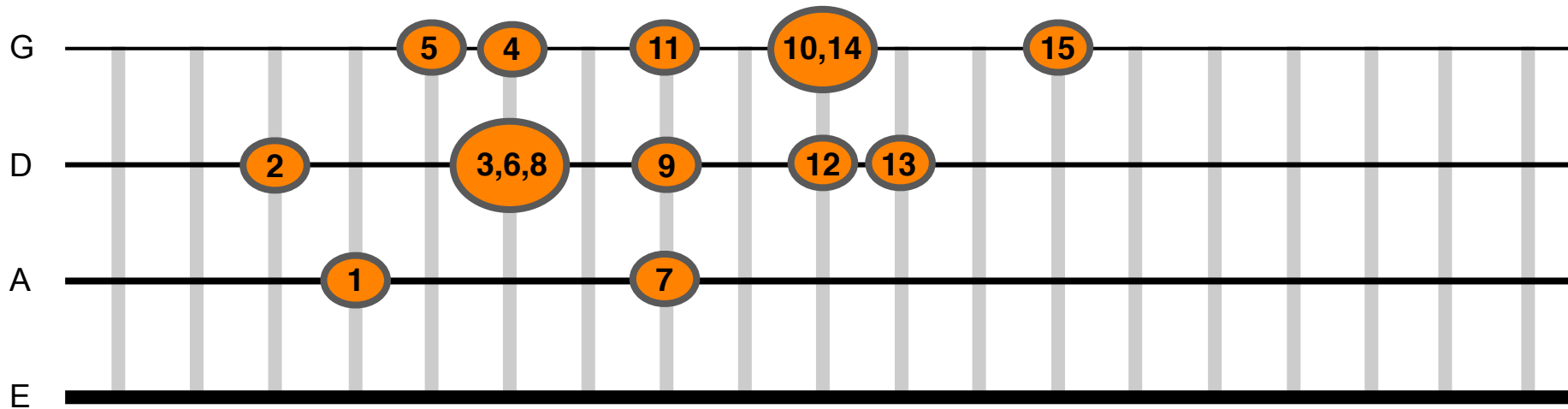

Eagle's Eye Overview Order of notes played

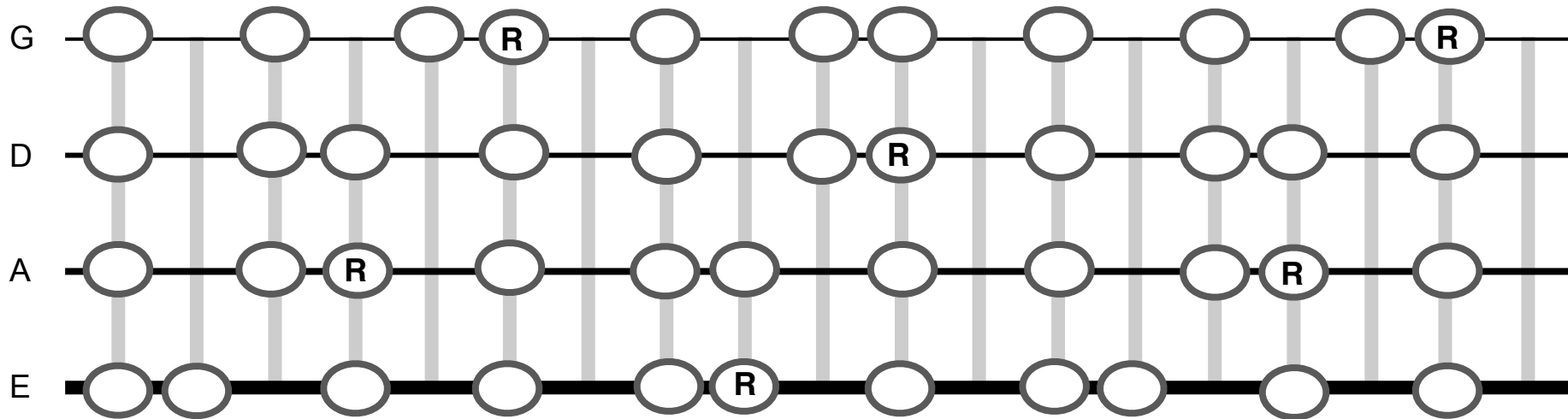

**Make some of your own shapes and patterns
fill in the appropriate scale tones
then map it out on your instrument**